



Prestressed Multihole Round Head Anchorage for PC Strand

Our Product Introduction

for more products please visit us on greycastironcasting.com

Basic Information

- Place of Origin: China
- Brand Name: NC8412
- Certification: ISO9001,CE,SGS
- Model Number: 8412
- Minimum Order Quantity: 100 PCS
- Price: Can talk
- Packaging Details: Wooden Case
- Delivery Time: 30 days
- Payment Terms: T/T, L/C
- Supply Ability: 80,000 pcs monthly



Product Specification

- Material: Steel
- Type: Multiholes
- Diameter: 12.7mm Or 15.2mm Strand
- Application: Construction
- Capacity: 1860MPa
- Hardness: 20-35HRC



More Images



Product Description

Prestressed Multihole Round Head Anchorage for PC Strand

Product Details

Matched with strand diameter of	12.7mm ; 12.9mm,15.24mm ;15.7mm, 17.8mm-18.5mm, 21.6mm-22mm
Tensile strength	1860Mpa
Yield strength	1675MPa
Hardness	20-35HRC
Static load test passed anchoring efficiency	$\eta_A \geq 0.95$ and elongation $\geq 2\%$
With-draw of wedge after stressing	$\lambda \leq 6\text{mm}$

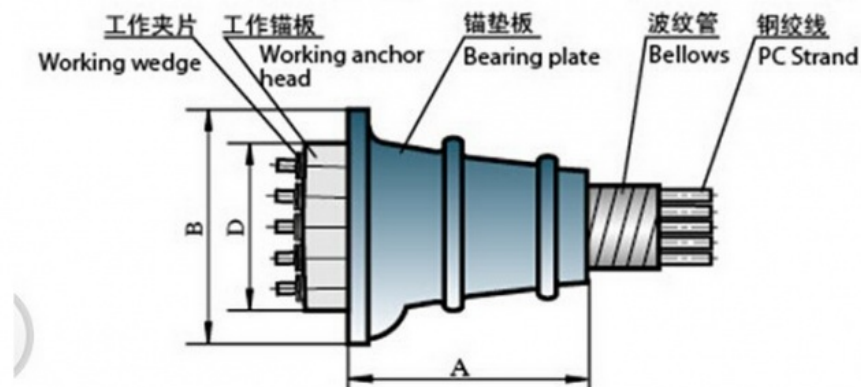

great quality best prestress anchorage wedges for pretension work

It includes some parts like limit board and anchor plate etc.

Its Hardness of manufacturer of industry wedge

work anchorage head and limit board: 25~4033HRC (306 HBS) work gripper :78~86HRA

Matched tensioning device manufacturer of industry wedge :

YCQQ series jack, ZB4-500 hydraulic pump

Heat treatment specification of manufacturer of industry wedge :

ISO9001 - 2008 & JB/T3999-1999

(Carburizing or carbonitriding and post-quenching and tempering of steel part)

During the Heat treatment permeability, nitriding, quenching, tempering process , The computer control process parameters of multi-purpose furnace, and set up quality control points according to the requirements of ISO9001 - 2008 quality assurance system, after heat treatment ,the hardness, tooth type, appearance have to pass a rigid thoroughly inspection, to ensure high qualified products.

All the procedure was controlled by a computer according to JB/T3999-1999

Quality Control



CMM



Tensile Test Machine



FAQ

Are you manufacturer or trade company? We are manufacturer.
We have been engaged in this field for 25 years.

What is your MOQ?

MOQ is different according to different kinds of product we can accept LCL .But we accept small quantity for trial order. Please contact us for details.

Can you print my own design or logo on the mug or other blank products?

Yes, we accept customization. Your logo and design will be warmly welcomed.

What is your delivery time?

For sample order: After the receipt of payment, usually it takes about 2-3 days to arrange samples.

For mass production: It takes about 7-15days depend on different kinds of item and order quantity.



Sunrise Foundry CO.,LTD



+86-15067447509



sales@greycastironcasting.com



greycastironcasting.com