



Steel Multi Strand Post Tension Anchor Round Anchor Head For Concrete Slab Anchor

Our Product Introduction

for more products please visit us on greycastironcasting.com

Basic Information

- Place of Origin: Ningbo China
- Brand Name: NC150
- Certification: ISO 9001
- Model Number: 150
- Minimum Order Quantity: 1 pcs
- Packaging Details: Wooden Case
- Delivery Time: 25 days
- Payment Terms: T/T, L/C
- Supply Ability: 80,000 pcs per month



Product Specification

- Type: Multi-hole Anchor
- Material: Steel
- Diameter: 15.24mm/12.7mm
- Capacity: 2000MPA
- Hardness: 20-35HRC
- Standard: ISO
- Highlight: **post tensioning system,
post tension accessories**



More Images



Product Description

Steel Multi Strand Post Tension Anchor Round Anchor Head For Concrete Slab Anchor

Description

Our main products include tensioning anchor, holding anchor, connectors, which have been widely adopted by modern construction, especially used in pre-tension or post-tension for concrete constructions and building materials

It can be used to lock the steel strand wires on / under classes of 2000Mpa standard strength, which is usually in diameters of 12.7mm / 12.9mm / 15.2mm / 15.7mm.

Product Details

Matched with strand diameter of	12.7mm ; 12.9mm,15.24mm ;15.7mm, 17.8mm-18.5mm, 21.6mm-22mm
Tensile strength	1860Mpa
Yield strength	1675MPa
Hardness	20-35HRC
Static load test passed anchoring efficiency	$\eta_A \geq 0.95$ and elongation $\geq 2\%$
With-draw of wedge after stressing	$\lambda \leq 6\text{mm}$



Our Advantages

1. Professional experience in prestressed industry and ISO9001, CE and MA certificates.
2. Customized Products: We can offer new product design, non-standard product design by our professional engineers.
3. 100% inspection.
4. After Sale Service and Technical Assistance.
5. On-time Delivery.
6. Less Cost of Purchase: We are a direct manufacturer to save intermediary cost.
7. OEM and ODM Service.

The consist of Bonded Flat Slab Anchor Posting Tensioning

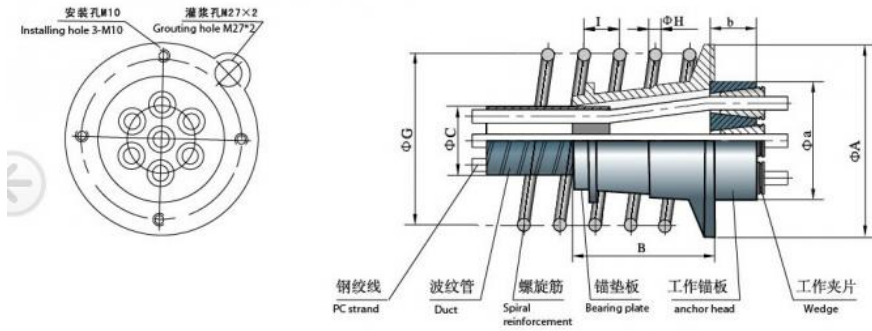

LQM15、LQM13型张拉端总成构造图
Structural chart of LQM15 and LQM13 tensioning end assembly

FAQ

Q1: What is your payment terms:

A1: TT: 30% deposit, balance before shipment.

CIF: 30% deposit, balance based on scanned

BL or LC 100% at sight

Q2: Can you supply stocks? Can you deal small orders?

A2: Yes, Small orders can also be accepted.

Q3: Do you provide samples? is it free or extra?

A3: Yes, we can offer samples free of charge. But the express cost should be on buyer's account.

Q4: If found the product with substandard quality. How can you solve it?

A4: The buyer will be required to submit proof file, picture, video of the said substandard cargo to us first. We can also send our engineer to your field to check it directly, if necessary.

Q5: If accept OEM service to made product as per buyer offering drawing?

A5: Yes, we can offer OEM service. manufacture product as per buyer's offering drawing.



Sunrise Foundry CO.,LTD



+86-15067447509



sales@greycastironcasting.com



greycastironcasting.com